

Controlling ESD In Automated Handling Equipment

By Donn G. Bellmore
System Engineering Analyst
Universal Instruments Corporation
PO Box 825
Binghamton NY 13902
Phone: 607 779 7471
Fax: 607 779 5256

Abstract: Manufactures of Automated Handler Equipment (AHE) are or should be continuously striving to control ESD in their equipment and protect the product being processed. As the product sensitivities to ESD become increasingly lower, controlling ESD is becoming more of a significant problem in the electronic assembly equipment. This paper deals with researching, and experimentation of many types of materials, finishes, grounding methods, and testing, using the ESD Associations Standard ESD SP10.1-2000. The results were a reduction in voltage levels in a magnitude of several thousand volts to less than 10 volts in prototype equipment.

I Introduction

As Automatic Handler Equipment (AHE) and Assembly equipment and the product they handle become more advanced, ESD control and prevention becomes increasingly important. Many End Users are now picking and placing devices with typical throughputs ranging from 20,000 to 38,000 components per hour. In the past, typical devices usually had susceptibilities greater than 400 volts Human Body Model (HBM). HBM does not really apply to AHE, however, the HBM rating is the only rating available for much of the customer's product. Many End Users are now trying to pick and place components with susceptibilities less than 100 volts Charged Device Model (CDM). At the existing placement rates, product damage can add up quickly. In order to achieve the higher rates of throughput and keeping the cost per placement as low as possible, many composite and polymer materials have been used for nozzles, vacuum cups, belts, guides, tracks, and adapters. Molded insulating polymer materials while typically less expensive than machined metal parts, increase the hazards of ESD by increasing the resistance of or obstructing ground paths. In addition they typically increase triboelectric charging. While their costs are attractive, great care must be exercised when selecting these materials. Dissipative and conductive polymers add a level of uncertainty by

changing the materials mechanical properties and electrical properties. For example, molds designed for one material may not work as well once 10% or 15% carbon is added to the resin due to changes in shrink rates and brittleness. Also, parts made from the polymer may not wear as well or they may wear differently after the addition of the conductive agent.

Proper design considerations must also be taken to insure proper grounding through bearings, slides, and hinges of the dissipative and conductive materials. Charge levels, charge rates, and dissipation rates all play important roles in controlling ESD especially when function rates of the newer handlers are in millisecond ranges. The minute function times also causes additional difficulties in the measurement process. Test equipment has to be responsive enough to catch the whole measurement for each function. Therefore, proper selection of the measurement devices is as critical as the selection of the proper materials.

In prototype equipment, static charges in terms of field strengths was found to be in excess of several thousands volts /cm at piece part levels. System levels were even greater and voltages imparted to the board level were in excess of 500 volts /cm. By using appropriate grounding methods and dissipative materials, piece part levels were reduced to a maximum of 10 volts /cm at a system level while still retaining many of the cost benefits derived from

moldable and extrudable polymers. Test methods were developed using ESD Associations Standard ESD SP10.1-2000 as a guide and were modified as discussed in the experiment section. This paper will discuss a number of generic assemblies, the experiments required, set ups, results, the conclusions, and the changes made in materials based on the results.

II Experiment

II.a Test Design

The design of the test had to address a number of design concerns such as ground paths, mechanical wear and electrical characteristics of a number of polymers used in several applications. To accommodate the areas of interest, several sets of experiments were conducted. The data for each experiment will be discussed individually where appropriate. Field strengths were measured using EOS/ESD Association SP10.1-2000 as a guide and resistance measurements were made following the recommendations [1]. The resistance of sample materials and prototype pieces were measured using a modified procedure of a megohm meter and probes. [2]

The selected materials were placed into the application and the performance was measured using modified standard practices. In some cases the measurement technique was modified to fit the process or the component paths and is discussed where appropriate.

II.b Material Tested

High Density Polyethylene (HDPE) Ultra High Molecular Weight (UHMW) Standard and with 5% and 10% Carbon Fill
Polyetherimide, standard and 10 % carbon reinforced Composite (Ultem)
Acetal Homopolymer (Delrin) standard and 10% Carbon Fill
Graphite Polyimide (Vespel)
Polyetherimide (Semitron 410)
Cerastat
Rigid ABS/PVC (Royalstat)
Polyoxymethylene, POM (Acetal) Carbon fiber filled Chemiflex standard and Carbon filled timing belts
NEY Conductive grease loaded radial bearings
Ceramic, (Zirconia) Standard
Ceramic, (Cerastat) Dissipative

II.c Equipment Used

NOVX Series 5000 Electrometer
Trek Model 368 Electrostatic Voltmeter
Trek Miniature probe with side aperture
Trek Miniature probe with end aperture
3M Model 701 Megohm meter, standard probes and customized probes
Fluke 8050A Bench DMM
Kiethly 199 System DMM / Scanner
Something Power supply
Monroe Model 253 Nanocoulomb Meter
Monroe Model 253/22A Faraday Cup
Tektronix TDS 420 Oscilloscope

II.d Test Setup

II.d.1 Applications Tested:

Drive Belts
Nozzle Materials
Theta Drive Materials
Ground paths of various applications
Bearings, Low Torque Theta radial bearings, ball bearings, and linear bearings
Component Guide Materials

When testing the various materials for the nozzles and other assembly parts, and the reaction of the processed components, both the Trek Electrostatic Voltmeter and the NOVX 5000 Electrometer were used to measure the field strengths and voltages. To determine the amount of charge on the components from either triboelectric charging or induced charging, the components were placed into a Faraday Cup.

II.d.2 Belt Measurements

As seen in Fig 1 the end aperture probe of the electrostatic meter is mounted approximately .080 inches (2.03 mm) away from the belt surface. The probe requires an insulative holder since the measured voltage is also on the body of the probe. The holder is held in position with a magnetic base indicator stand.

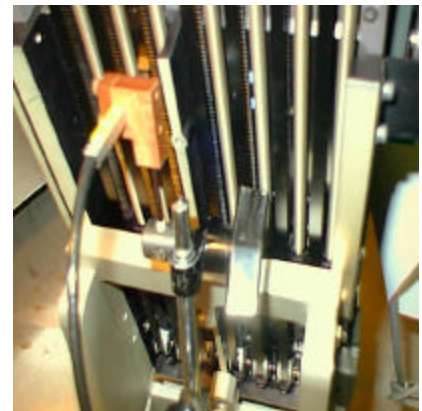

Figure 1

The timing belts in the photo are a carbon filled urethane timing belt that replaced the standard urethane-timing belt.

II.d.3 Nozzle Materials

The following illustrations indicate the position of the nozzles, probes, and Faraday Cup at various stages of measurements. Also illustrated is the setup with the nozzle and component passing over a proximity sensor of an electrostatic meter. The sensor was set up so that the nozzle carrying a component picked by the nozzle under test, passed over the sensor at a .5 inches (12.7 mm) at the average travel speed of 70 inches (1788 mm) per second. Due to the speed of the component passing over the sensor, the measurements were recorded using an oscilloscope and the meter analog output. Since the relationships between static and dynamic measurements were uncertain, correlation of the measurements was required. [1] The correlation of field strengths were accomplished by passing a component of the same size with a known charge over the sensor at the same gap and speed. The correlation is discussed in the results.

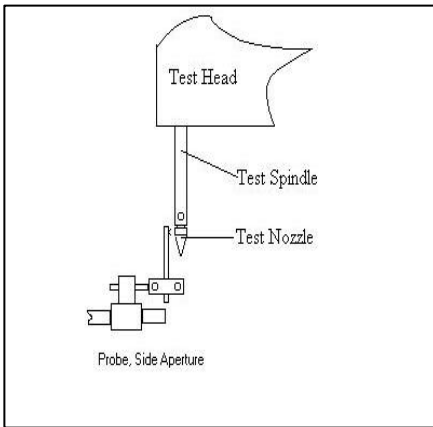

Figure 2

The nozzle materials were interchanged after each set of measurements were completed. The head was programmed to extend the spindle with the nozzle on it to a preset coordinate placing the side aperture probe at the correct gap of .08 inches (2.03 mm) after simulating picking and placing 120 components. This method of testing proved repeatable and because the device under test paused over the probe and it is a direct measurement, there is no need for correlation of the measurements. Please see the results section for measurements.

As seen in Figure 3, the field strength intensity was measured on the component by using an end aperture probe and electrostatic meter. Again in this test, the same test head was used as discussed previously. The

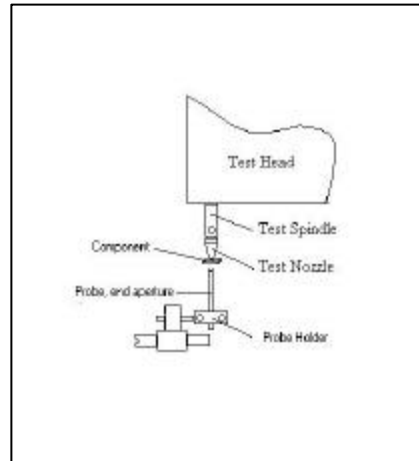

Figure 3

apparent that the nozzle would have to simulate picking many components using one component to increase the charge on the component in order to obtain a measurement. As in the previously discussed nozzle material test, there was no need for correlation since the device paused over the probe resulting in a static measurement. To satisfy a curiosity, an experiment was setup with the component slewing past the probe at full speed, with an oscilloscope connected to the analog output, there was a very close correlation in the paused or static measurements and the dynamic measurements. Please see the results and conclusions.

Figure 4 depicts the same head as previously discussed picking devices from a matrix tray. Also as

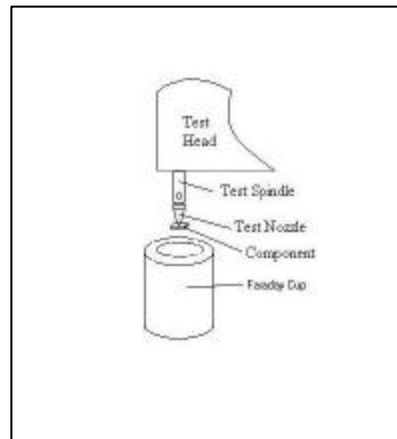

Figure 4

previously discussed, the devices were dropped into a Faraday Cup for measurements, which were very unstable with a wide range of variation. It is possible that dropping the component in the cup and the variation in the component's settled position caused the variation in measurements. Due to variation and instability of the measurements, this test method was not used in this experiment and is not part of these results. It is mentioned only to document the method and explain why it was not used.

component was picked from a matrix tray. Previous to this test, an ionizer was used to neutralize any charges on the tray and the components were measured. In some cases it

became

Figure 5 exhibits the same test head and nozzle passing over the electrostatic meter's proximity probe with a .5 inches (12.7 mm) gap. Multiple measurements can be made in this manner very rapidly but correlation of the measurements and the actual field strength are required for each component tested as well as for each

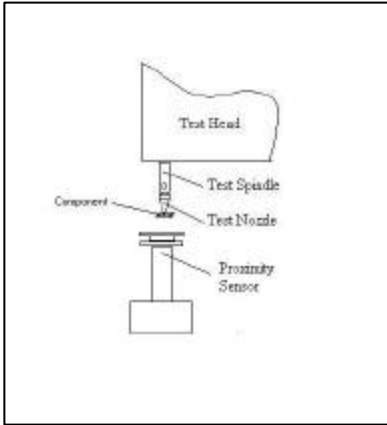

Figure 5

speed and distance over the sensor. Also as seen in the results, for a single component, the correlation was not completely linear at the very low end. This will be discussed in more detail in the conclusions.

II.d.4 Theta Drive Gears:

As seen in Figure 6, the Theta Drive Gear was tested in its application.

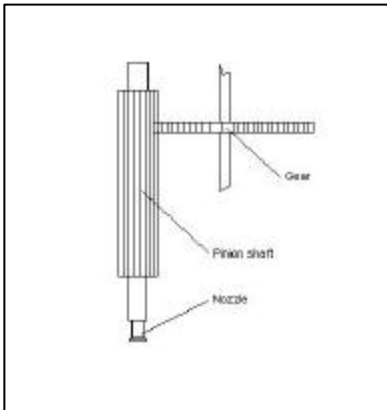

Figure 6

theta gear rotates the shaft and component to the desired rotation. The illustration shows the nozzle extended.

II.d.5 Ground Paths

Figure 7 illustrates the ground path through the nozzle pick up, spindle, bearings, and finally the housing to chassis ground. Typical precision radial ball bearings with low torque preloads used in guiding spindle rotation (Theta) were used as a ground path. The spindle connected the nozzle adapter and nozzle to the bearings. The nozzle adapter is a conductive polymer. Radial ball bearings packed with conductive grease were also tested to determine if the conductive grease

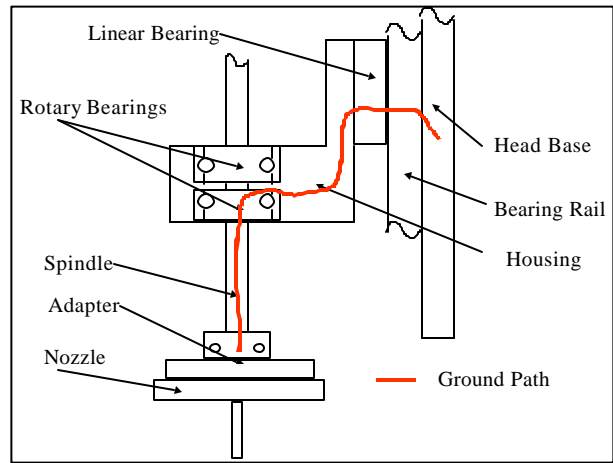

Figure 7

would reduce the ground path resistance and not degrade the bearing life.

Figure 8 is another type of drive connecting and controlling the nozzle (not shown) through the adapter. The ground path should be from the tip through the

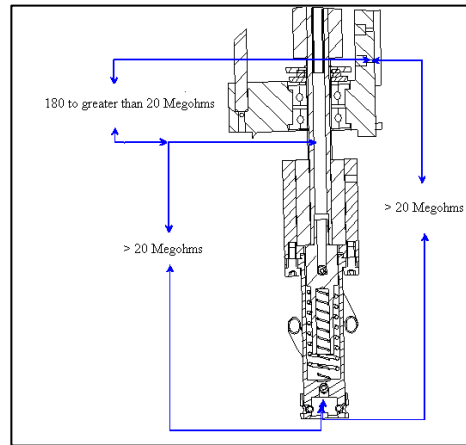

Figure 8

linear bearing to chassis ground and should be less than 1 megohm. [1] As seen in the Illustration, the resistance is greater than 20 Megohms.

Anodized Aluminum was used as a plating and on all surfaces and bores. While anodized aluminum may be a dissipative finish and great for controlling ESD [3], it is not a good conductor for ground path applications.

The ground path was through the anodized surfaces, the spindle, radial ball bearings and the adhesives, the housing, and finally the linear bearings. Setscrews breaking the anodized surface and adhesives in most cases provided the only ground path. In many cases the ground path after several million cycles was nonexistent or at best intermittent.

Figure 9 is the final configuration a nozzle holder. The anodized plating and insulating adhesives were removed. Conductive Chromate was used on mating surfaces and in bores replacing anodized plating. In

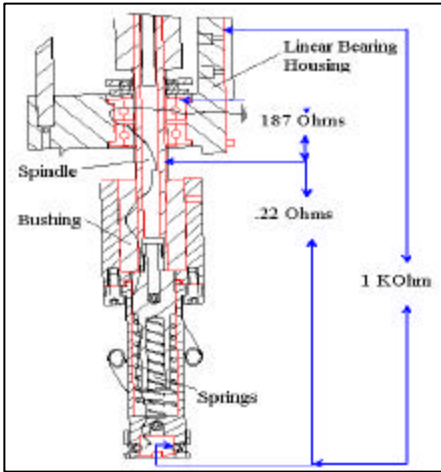

Figure 9

the spring bores, a natural finish was used. There were concerns that without plating, corrosion may cause higher resistance and even intermittent connections.

Slight press or line-to-line fits were used instead of adhesives. NYE conductive grease was used in the radial bearings. The assemblies were assembled using conductive hardware.

II.d.6 Pulleys

Drive Belt pulleys were grounded by using pulleys with bronze bushings or radial ball bearings with inner raceway connected to chassis ground with either pins or assemblies designed for durability and ground paths. A number of pulleys were coated with Titanium Nitride to reduce corrosion and to further reduce the contact resistance between the belt and the pulley.

II.d.7 Rotary Ball Bearings

Rotary Ball Bearings were tested in timing belt and drive belt applications and were standard from the manufacture without conductive lubricants.

II.d.8 Linear Bearings

Linear bearings were tested, as they were installed and stock from the manufacture without conductive lubricants.

II.d.9 Component Guides

Figures 10 and 11 show the component guide setup used in this test in guiding printed circuit boards through a conveyor system. The edge guides were the application under test. Delrin and UHMW were tested.

In another application, a clear polycarbonate cover was required to captivate and guide scrap on an exit chute and they were tested in application.

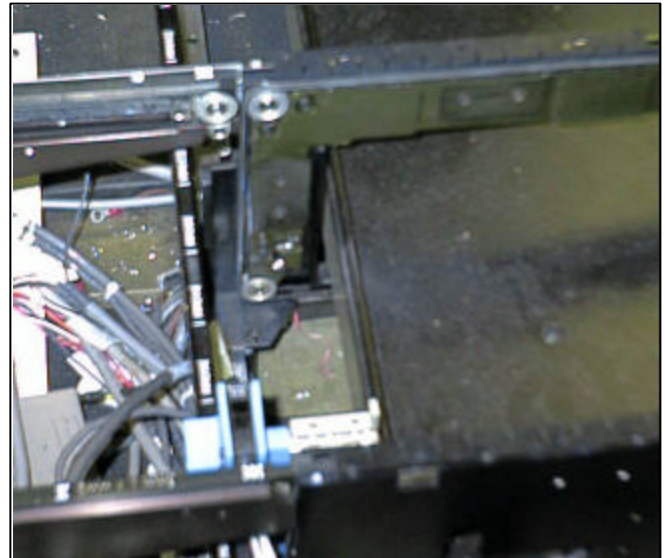

Figure 10



Figure 11

III Results

III.a Drive Belts

Voltage Field Strength levels in excess of several thousand volts/cm on the drive belts within several inches of the component paths were reduced from 736 volts/cm to 10 volts/cm at 40% RH by using dissipative materials and grounded pulleys. At 12% RH, the voltage/cm was reduced from 2000 volts to 10 volts. See Data, Table 1

| Belt Type | V/cm @ 12% RH | @ | V/cm @ 40% RH |
|------------------------------|---------------|---|---------------|
| Urethane, Standard, Long | > 2000 | | 736 |
| Urethane, Dissipative, Long | 10 | | 10 |
| Urethane, Standard, Short | >2000 | | 1000 |
| Urethane, Dissipative, Long | 10 | | <10 |
| Urethane, Standard, Z | >2000 | | >2000 |
| Urethane, Dissipative, Z | 10 | | 10 |
| Urethane, Standard, Theta | >2000 | | >2000 |
| Urethane, Dissipative, Theta | <10 | | <10 |

Table 1, Belts were measured at 12% & 40% RH at 70 Degrees F

The life of the belt did not appear to decrease with the addition of carbon

dissipative polymers and by providing ground paths. It is important to note here that without an established ground path, the dissipative and conductive nozzles charged to 290 volts/cm.

Graph 1 displays the relationship between dissipative, non-dissipative, and Cerastat ceramic nozzles in partially grounded, non-grounded, and appropriately grounded systems as the nozzles simulate picking and placing a 100 pin quad flat packs (100 QFP) in an environment of 72 degrees F and a RH of 40%. For more information see the materials table in the conclusion section.

III.d Theta Drive Material

The insulative delrin material used for a large gear that rotates the spindle charged to over 2000 volts/cm, while the Acetel material charge to only 26 volts/cm. There was no degradation in performance with the dissipative material.

Table 2

| Gear | Volts/cm @ 40% RH |
|---------------------|-------------------|
| Standard Theta Gear | 2000 |
| Acetel Theta Gear | 25.6 |

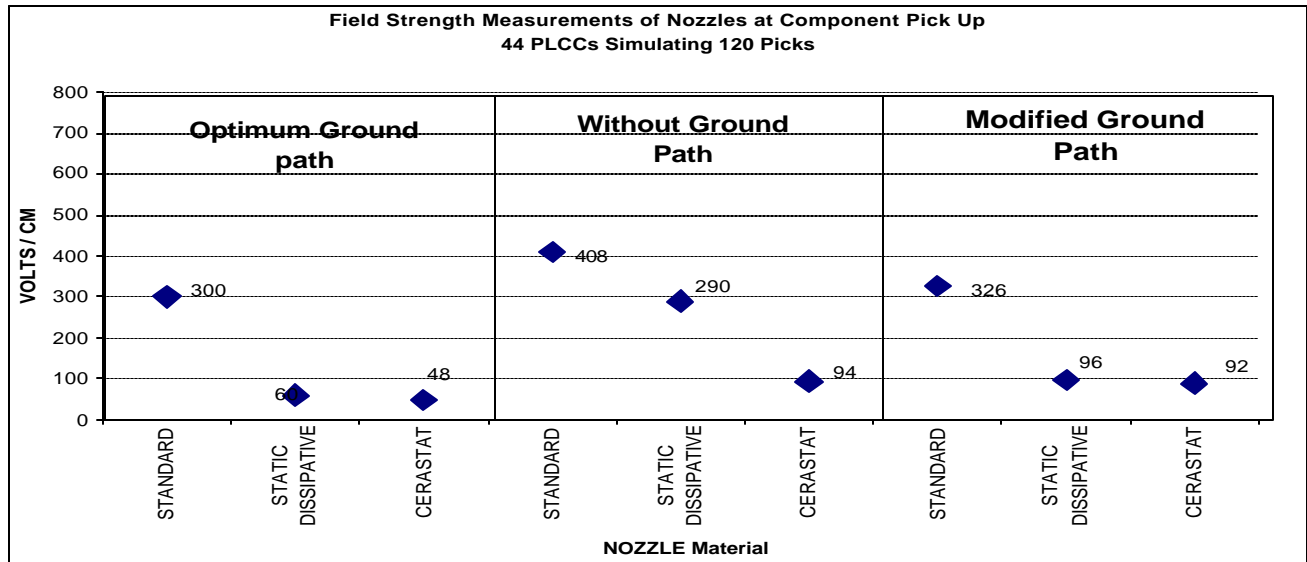

Graph 1

III.b Pulleys

The ground path resistance through the pulleys and bushings or radial bearings never exceeded 1 Megohm.

III.c Nozzles

Nozzles and nozzle adapters were reduced from 408 volts/cm to 60 volts/cm using conductive and

III.e Ground Paths

As depicted in Illustration 6, as tested the resistance measured between $5e^5$ to $1e^6$ ohms of resistance. After 30 to 50 million cycles the resistance typically increased to $7e^6$ to $10e^6$ ohms. After the addition of conductive grease, the resistances remained less than 200 ohms and in some measurements were as low as 10 ohms.

As tested in Illustration 7, the ground path resistance exceeded $10e^{10}$ ohms.

After incorporating the changes as depicted in Illustration 8, the ground path resistance was reduced to less than $10e^6$ ohms and promoted consistent manufacturability. In most cases the resistance was as low as 1000 ohms but would vary. While it did vary, the maximum measurement never exceeded .8 Megohms.

III.f Low Torque Radial Bearings

The low torque bearings tested resulted in a decreased resistance through the races and balls from 300 ohms to less than 10 ohms. In some cases the standard bearings with a higher preload (tighter press into a the bore) exhibited lower resistance that would increase after running a few million rotations. The addition of conductive grease provided a consistent lower resistance over time. From a wear perspective, the bearings are designed to run for millions of rotations and the wear test remains in progress.

III.g Linear and Ball Bearings

These bearings did exhibit an increase in resistance over time, from 10 ohms to 100 ohms.

III.h Pulleys

The pulleys tested were grounded by the same ball bearings described in the ball bearing results and bronze bushings that remained low in resistance to ground. The typical resistance fell between less than 10 ohms to 100 ohms

III.i Component Guides

Printed circuit board guide resistance was reduced from insulator values to $10e^6$ ohms by using dissipative materials and with proper grounding does not develop a charge. The printed circuit boards passing through the guides did not develop a charge. Dissipative UHMW and Delrin are used for their mechanical properties as well as their electrical characteristics.

The clear polycarbonate covers were the only choice in this application, other materials tested performed satisfactory but the transparency was an issue. The

polycarbonate was coated with a permanent conductive coating with a resistance less than 10^6 ohms. With proper grounding, the covers did not build up a charge.

III.j Correlation of 2 measurements

The correlation of the proximity sensor readings to the actual voltage/cm measurements is exhibited in Graph 2. As indicated, there is a slight difference towards the lower end of the measurements. However, the upper levels of measurement appear to be linear.

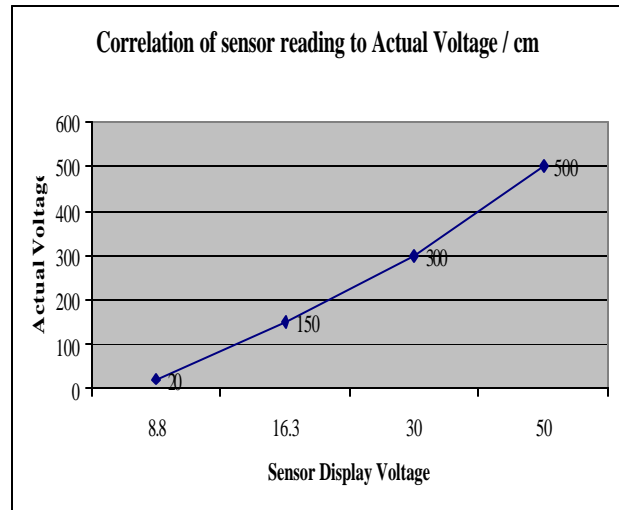

Graph 2

The electrostatic meter and miniature probes, in this application, component, and travel speed of the component, demonstrated a 1:1 correlation between static and dynamic measurements.

The Material Table, Table 3, contains the results of testing various materials in the described applications and the values of resistance and voltages/cm were typical of their characteristics. It is meant to be more of a reference and a starting point than hard results since there are many variables in the associated applications.

| Temperature 70 Degree F. | | | 40% RH | 40% RH |
|-----------------------------|---|---|-------------------|--------|
| Brand | Generic Name | Applications | Ohms | V/cm |
| Delrin | Acetal Homopolymer Dissipative | Nozzle Tips & Bodies / Guides / Covers | 10 ⁶ | 50 |
| Delrin | Acetal Homopolymer | Nozzle Tips & Bodies / Guides / Covers | >10 ¹¹ | 300 |
| ULTEM | Polyetherimide Dissipative | Nozzle Tips & Bodies / Guides | 10 ⁶ | 50 |
| ULTEM | Polyetherimide | Nozzle Tips & Bodies / Guides | >10 ¹¹ | 2000 |
| UHMW | High Density Polyethylene (HDPE) Dissipative | Nozzle Bodies & Guides | 10 ⁵ | 35 |
| UHMW | High Density Polyethylene (HDPE) | Nozzle Bodies & Guides | >10 ¹¹ | 2000 |
| Vespel | Graphite Polyimide | Nozzle Bodies & Guides | 10 ⁴ | 30 |
| Semitron | Polyetherimide | Tips / Bodies | 10 ³ | 60 |
| Acetal | Polyoxymethylene (POM) | Guides & gears | 10 ⁴ | 26 |
| EFI | Urethane | Compliant Tips | >10 ¹¹ | 1000 |
| EFI | Urethane, Dissipative | Compliant Tips | 10 ⁸ | 20 |
| Royalstat | ABS/PVC | Covers | 10 ⁴ | 30 |
| Zirconia | Ceramic | Nozzle Tips | >10 ¹¹ | 300 |
| Cerastat | Ceramic | Nozzle Bodies | 10 ⁴ | 48 |
| Cermax | Ceramic | Nozzle Tips | 10 ⁶ | 10 |

IV Conclusions

1. With modern day test equipment, effective and accurate measurements can be made following the Standard Practices contained in ESD Association SP10.1-2000 as a guide.
2. When using proximity or field strength instrumentation in applications of high speed and short response times, correlating the voltage measurements to known sources at the same speed is necessary to obtain accurate measurements as specified in the ESD Association SP10.1-2000. [1] Correlation of the proximity measurement to actual field strengths has to be made for each specific experiment where size, distance, and / or travel speed over the sensor may change. The

correlation has to be completed using the same set of parameters as the experiment in order to obtain the correct data.

The electrostatic meter and miniature field strength probes used were unaffected by the application's slew speed of the equipment being measured in this application. The measurements using the probes were made in a static manner, therefore not requiring correlation.

3. Following the grounding guidelines in Appendix A of ESD Association SP10.1-2000 is an excellent starting point in the design of AHEs in terms of grounding and ground paths.

4. As seen in Table 1, adding carbon to urethane belts reduces the charge developed on them. By changing all of the urethane belts to dissipative urethane, the charges that developed and consequently the fields were of a low enough level not to be of a concern. Especially in these applications since these belts do not come in physical contact with the devices. The dissipative belts, urethane with carbon, do not appear to be affected by humidity. Belt wear appears to have been improved with the dissipative belts, however, the tests are ongoing.
5. There were a multitude of nozzle material combinations tested; many for wear considerations as well as static control. Basically, as seen in Graph 1, the results of the test indicate that dissipative materials will reduce the amount of charge on the nozzles as long as there is a sufficient ground path. Even conductive materials will develop a charge if isolated from ground. The dissipative polyetherimide (Semitron 410) was selected for most nozzle applications because of its excellent wear characteristics as well as its electrical properties. There were materials with better electrical characteristics such as Cerastat, and materials with better wear or mechanical characteristics but both characteristics had to be considered. The Semitron is the best of both worlds for this application
6. The Theta Drive material was important since when extended as indicated in Figure 6, the gear is at a distance from the nozzle and device, however, when retracted, the gear was in close proximity to the device being processed. With the standard material building such a high charge as indicated in Table 2, induced charging of the device was a real concern. Consequently the dissipative Acetal material reduced the level of charging and did not reduce the life of the gear.
7. The proper ground path and method is as important a selection as the materials chosen. Without a path to dissipate the charge from the dissipative or conductive material, the material will build up a charge. If the resistance is too high, it will take too long to dissipate the charge. In these test as illustrated in Illustrations 6 to 8, the ground path was non-existent at the start of the design. In the final configuration, the ground path was consistent, manufacturable, and sufficient to dissipate the charge in a time compatible with the function. These are all design concerns that need to be addressed in the beginning of the design.
8. The low torque radial bearings are designed for a very light load and low torque required to rotate the bearing unlike ball bearings used on belts and other drive systems. The contact resistance is high due to low contact force. As the bearings wear, they produce oxides that further increase the resistance through them. The conductive grease fills the voids with conductive particles that provide a greater surface area and contact reducing the contact resistance.
9. Conductive greases are very useful in providing a good ground path without reducing the life of the bearings. As with other lubricants, they are available in different types designed for different temperatures and conditions. Their selection is very dependent on the application and requires good communications with the suppliers.
10. While the Linear and Ball Bearings did increase in resistance with time, they were well within the range of acceptability. The ball bearings maintained a lower resistance due to the higher loading on the balls and races providing higher contact force. The linear bearings have a higher preload than the low torque radial bearings and a lower preload than ball bearings. The reason they maintain a low resistance is due to the number of balls in contact with the races, which provide a higher contact surface. Most quality linear bearings have wipers that also seal out contaminants that would increase the resistance over time.
11. The pulleys of the belts tested when grounded through their attachment process appear to provide sufficient grounding for the belts. As mentioned in the setup of these tests, some of the pulleys were plated with Titanium Nitride. From a ground path consideration, there was no apparent difference between the plated pulley and the natural finish pulleys. Cosmetically, the Titanium looks much better,

however, it wears off as well, leaving the natural material exposed.

12. Component guides have a number of considerations in the material selection, PC boards are very abrasive, many of the devices handled are abrasive and have sharp edges that can scrape and wear the surfaces away in a short time on the wrong material. The component guides also have to be in a specific range of resistance at the point contact with the device or board to prevent rapid dissipation and high currents or insufficient dissipation and charging. The dissipative UTEM and Delrin at the tested surface resistance provided the proper balance of controlled dissipation.
13. In some applications, due to cosmetics or just having to see what is taking place, transparent materials are required. It is very difficult to get conductive or dissipative materials for this application. Coating polycarbonate with a conductive transparent coating is a good solution as long as sliding contact is not an issue. While the coating holds up to an occasional scuff, it will not withstand a lot of sliding pressure.
14. As seen in the Graph 1 and in the Data, with the proper use of materials, voltage levels can be reduced to levels allowing safe automatic handling of components rated 20 to 50 volt CDM and MM susceptibilities depending on the component type and configuration.
15. Reliability is a very large concern of end users of AHEs and working closely with suppliers and using carefully selected materials can reduce static charges to an acceptable level without sacrificing reliability. The ESD materials either performed as well as or out performed the standard material. A number of life tests are still in progress and have not been finalized.

IV.a Comments indirectly related to this work

1. In researching customers needs and requirements, it has become painfully obvious that the typical end user of components in their assembly work whether Contract Electronic Manufacturing or Original Equipment Manufacturers do not or cannot obtain accurate sensitivities of the

components they are trying to handle with automated equipment. HBM does not typically apply in the AHEs since operator intervention is or should be very limited. More education of end users is obviously more necessary now than ever before.

2. Additional work is needed in specifying AHEs properly. The old specification of "no more than 150 volts within the system" is still used all too much.

V Acknowledgements:

I would like to thank Mr. Mike Sotak, Industrial Engineering Specialist who conducted many of the experiments, and Mr. James Lamuraglia, Systems Engineering Manager, for support and editing assistance.

VI References

- [1] EOS/ESD Association SP10.1-2000
- [2] EOS/ESD Association STM4.1-1997
- [3] Anodized Aluminum Alloys Insulator or Not, 2001 ESD Symposium
- [4] Machinery Handbook, 24th Addition